

## Standard specifications

The low profile rough terrain SLP Series forklift is ideally suited for work in tight spaces. Featuring a proven drivetrain, tight turning radius, and ROPS/FOPS overhead guard, this forklift is an exceptional performer on any surface.



### Engine

**KOHLER KDI 2504 TCR** Tier 4 engine does not require exhaust aftertreatment. Diesel Particulate Filter (DPF) and Diesel Exhaust Fluid (DEF) are not required reducing operating costs. Engine is equipped with fuel/water separator with hand primer, dual element air filter, air pre-cleaner, cold weather starting aid & vertical exhaust.

### Transmission

Four-speed power reversing synchroshuttle transmission with torque converter and integral parking brake. 4-speed fully automatic transmission standard on 4WD models.

### Axles

High load capacity drive & steer axles provide less wear and low maintenance. Limited slip differential provides increased traction.

### Brake system

Enclosed multi-disc, oil-immersed service brakes with mechanically-operated, lever applied, parking brake.

### Steering

Load sense power steering.

### Instruments

Full instrument package includes warning indicator lights & gauges.

### Mast assemblies

Sellick SEE-THRU® all-roller mast design. A wide range of two or three-stage available with maximum lift height up to 22 ft. Mast sideshift: 6" total.

### Standard equipment

- Suspension seat w/seatbelt\*
- 2 front & 2 rear halogen worklights
- LED brake & amber flashing lights
- Neutral safety start
- Tilt steering wheel
- Horn & backup alarm

\*Suspension seat standard on 85" platform only

### Optional equipment

- Fully enclosed cab with heat
- Hydraulic fork positioning
- AM/FM/MP3
- Cold weather package
- Solid cushion tires

# SLP SERIES

## TECHNICAL SPECIFICATIONS

Lift capacities of 5,000, 6,000 or 8,000 @ 24" load centre

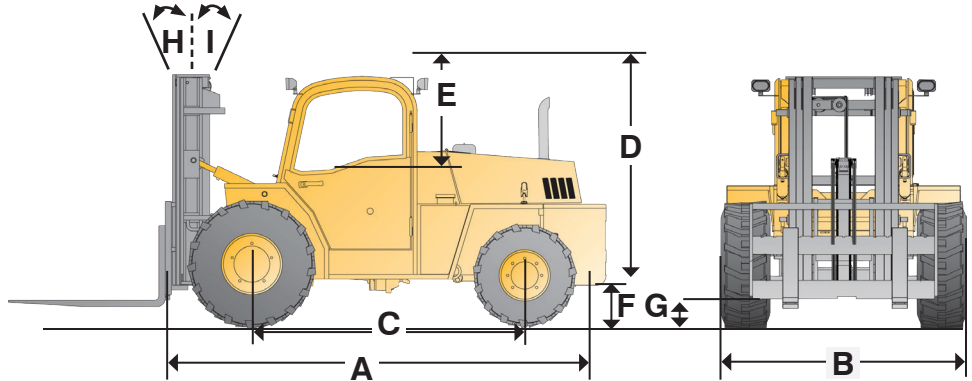

Model	Ref	SLP50	SLP60	SLP80
Lift capacities @ 24 inch load centre		5,000 lbs	6,000 lbs	8,000 lbs
Total weight (w/2 stage mast)		11,000 lbs	12,600 lbs	13,700 lbs
Overall length (without forks)	A	147"/3,734 mm	147"/3,734 mm	152"/3,861 mm
Overall width	B		78"/1,981 mm	
Wheelbase	C		93"/2,362 mm	
Height to top of overhead guard	D		75"/1,905 mm 85"/2,159 mm	
Distance from seat to OHG	E		40"/1,016 mm (75" OHG) 45"/1,143 mm (85" OHG)	
Outside turning radius		in 2WD mode: 178"/4,521 mm; in 4WD mode: 196"/4,978 mm		
Frame underclearance	F		11"/279 mm	
Mast underclearance	G		12"/304 mm	
Mast sideshift			6"/152 mm	
Mast tilt - forward	H		20°	
Mast tilt - rearward	I		10°	
Gradeability			25%	
Tire size			Drive: 15-19.5-12 ply Steer: 12-16.5-10 ply	
Engine manufacturer & model		KOHLER KDI 2504 TCR - Tier 4 Final		
Cylinders		4		
Engine output (gross power)		74 hp @ 2,600 rpm		
Peak torque		221 ft-lbs @ 1,500 rpm		
Travel speed		15(24) mph (km/h)		

*Because of our constant dedication to product improvement, all specifications are subject to change without notice.*

All Sellick forklifts meet or exceed all ANSI B56.6 safety standards.



### Sellick Equipment Limited

P.O. Box 1000/2131 Roseborough Rd  
Harrow, Ontario, Canada • N0R 1G0  
519-738-2255 • sellick@mnsi.net  
www.sellickequipment.com



Sold & serviced by: